



## ENGINE

Model	FPT F5H FL463 A
Emissions Certification	Tier 4 Final
Type	4-stroke
Cylinders	4
Bore/Stroke	3.9 x 4.3 in (99 x 110 mm)
Displacement	207 in <sup>3</sup> (3.4 L)
Fuel injection	High pressure, common rail injection
Fuel	Diesel
Fuel filter	Spin on, Beta (4) = 20
Air filter	Dry type element w/ warning restriction indicator
Exhaust aftertreatment:	Cooled Exhaust Gas Recirculation (CEGR) w/ Diesel Oxidation Catalyst (DOC)
Radiator:	
Core type	All aluminum
Fan:	
Style	Direct drive
Lubrication/cooling oil pump:	
Style	Integral
Engine oil:	
Pump:	Rotor Pump w/ deep sump pan, plate cooled & pressurized under piston nozzles
Pump operating angle ratings:	
Side-to-side	Rated 35°
Fore and aft	Rated 35°
Oil filtration	Spin on, full flow
Engine speeds	RPM
Rated – full load	2500
Low idle	950
High idle – no load	2500
Horsepower @ 2500 RPM:	
Gross	74 hp (55 kW)
Net	70 hp (52 kW)
Peak torque @ 1400 RPM:	
Gross	232 lb-ft (314 N-m)
Net	227 lb-ft (308 N-m)

NOTE: Gross horsepower and torque per SAE J1349.  
Net horsepower and torque per SAE J1349.

## DRIVETRAIN

Transmission	Hydrostatic transmission	
Pump relief	6,092 psi (42 000 kPa)	
Pump flow @ 2500 RPM	37.0 gpm (140 L/min)	
Differential:	Open standard/limited slip or 100% lock opt.	
Front axles:		
Differential ratio	3.67	
Planetary ratio	6.00	
Final axle ratio	22.00	
Gear box:		
1st ratio	2.46	
Gear box HS:		
1st ratio	2.75	
2nd ratio	1.16	
Planetaries	Outboard	
Service brakes:	Master cylinder hydraulically actuated, wet disc on front axle	
Parking brake:	Mechanical, caliper on front axle	
Travel speeds	Forward	Reverse
	mph (kph)	mph (kph)
1st Low	3.7 (6.0)	3.7 (6.0)
2nd High	12.4 (20.0)	12.4 (20.0)
Travel speeds – HS	Forward	Reverse
	mph (kph)	mph (kph)
1st Low	3.3 (5.3)	3.3 (5.3)
2nd High	8.9 (14.4)	8.9 (14.4)
3rd High	20.6 (33.1)	20.6 (33.1)

NOTE: Travel speeds at full engine throttle  
w/ 365/80 R20 tires.

## ELECTRICAL

Voltage	12 Volts
Alternator	120 amp
Batteries	95 AHR, 900 CCA

## OPERATOR ENVIRONMENT

ROPS: ISO 3471: 2,008 lb (6 800 kg); Base and Deluxe Cab w/ heater and A/C; Key start; Articulated power steering w/ tilt column; Full adjustable, cloth suspension seat; Foot throttle; Single joystick w/ electronic speed shift control F/N/R switch and proportional loader control; Cup holder; Retractable seat belt; Storage tray on Deluxe Cab; Sun screen – front; Opening side window; Dome light; Wipers – front and rear; 12-volt auxiliary power; Lighter cigar and ashtray; Pocket cellular phone; Coat hook; External rearview mirrors; Loader control lockout.

Electronic information center

Displays/Gauges:

Vehicle speed; Hourmeter; Floating functionality on; High flow functionality on; Clock; Vehicle directions; Gear number engaged; PM Catalyst icons.

Indicator lights:

Diff. lock; Main hydraulic enabled; Turn light – left and right; Rear work lamps; Work lamps; Main high beam; Side lights; Stop; Warning signal; Rabbit; Hand brake; Brake fluid level; Quick coupler on; Ride Control on; Creep speed; PM Catalyst; Low fuel level; Clogging air filter; Engine oil pressure; Glow plug; Alternator changing.

Audible alarms:

Caution alarm; Critical alarm; Backup alarm.

Horn

NOTE: If equipped w/ option.

## OPERATING WEIGHT

Z-Bar:

Unit equipped w/ ROPS/FOPS cab w/ heater, standard HD counterweight, 365/80 R20 Dunlop tires, front and rear fenders, 1.3 yd<sup>3</sup> (1.0 m<sup>3</sup>) general purpose bucket w/ edge, full fuel, 165 lb (75 kg) operator:

13,633 lb (6 184 kg)

## HYDRAULICS

Pump – steering/implement:

Open-centered pressure/flow compensated

Fixed gear type:

Standard flow:

Max. 22.5 gpm @ 3,336 psi  
(Max. 85 L/min @ 230 bar)

Optional high flow:

Max. 34.3 gpm @ 2,901 psi  
(Max. 130 L/min @ 200 bar)

Loader control valve:

Open-center, Hydraulic Loader Control w/ single lever includes: Forward/Neutral/Reverse switch, Floating switch, Low/High Travel mode switch, Auxiliary Function Roller

Loader auxiliary steering

Main relief pressure 3,336 psi (23 000 kPa)

Filtration:

15-micron, full flow replaceable cartridges on return line

## SERVICE CAPACITIES

Fuel tank	22.7 gal (86.0 L)
Hydraulic system:	
Reservoir	10.6 gal (40.0 L)
Total	14.0 gal (53.0 L)
Front and rear axle:	
Front axle	2.3 gal (8.7 L)
Rear axle	2.6 gal (10.0 L)
Rear axle HS	2.5 gal (9.5 L)
Engine oil w/ filter	1.8 gal (7.0 L)
Cooling*	3.4 gal (13.0 L)

NOTE: \*1.72 gal (6.5 L) antifreeze + 1.72 gal (6.5 L) water.

## OTHER SPECIFICATIONS

Lift cylinders	Two (2)
Bore diameter	3.25 in (82.5 mm)
Rod diameter	1.97 in (50.0 mm)
Stroke	29.57 in (751.0 mm)

Tilt cylinder:	
Bore diameter	3.49 in (88.7 mm)
Rod diameter	2.25 in (57.1 mm)
Stroke	19.96 in (507.0 mm)

Loader:  
 Z-Bar loader linkage  
 Single control for lift and tilt  
 Positive hold float  
 Hydraulic attachment coupler:  
 Skid steer compatible/horizontal  
 pin compatible

Cycle time:	
Z-Bar:	
Raise w/ rated bucket load	5.8 sec
Dump w/ rated bucket load	1.7 sec
Lower – empty	3.8 sec

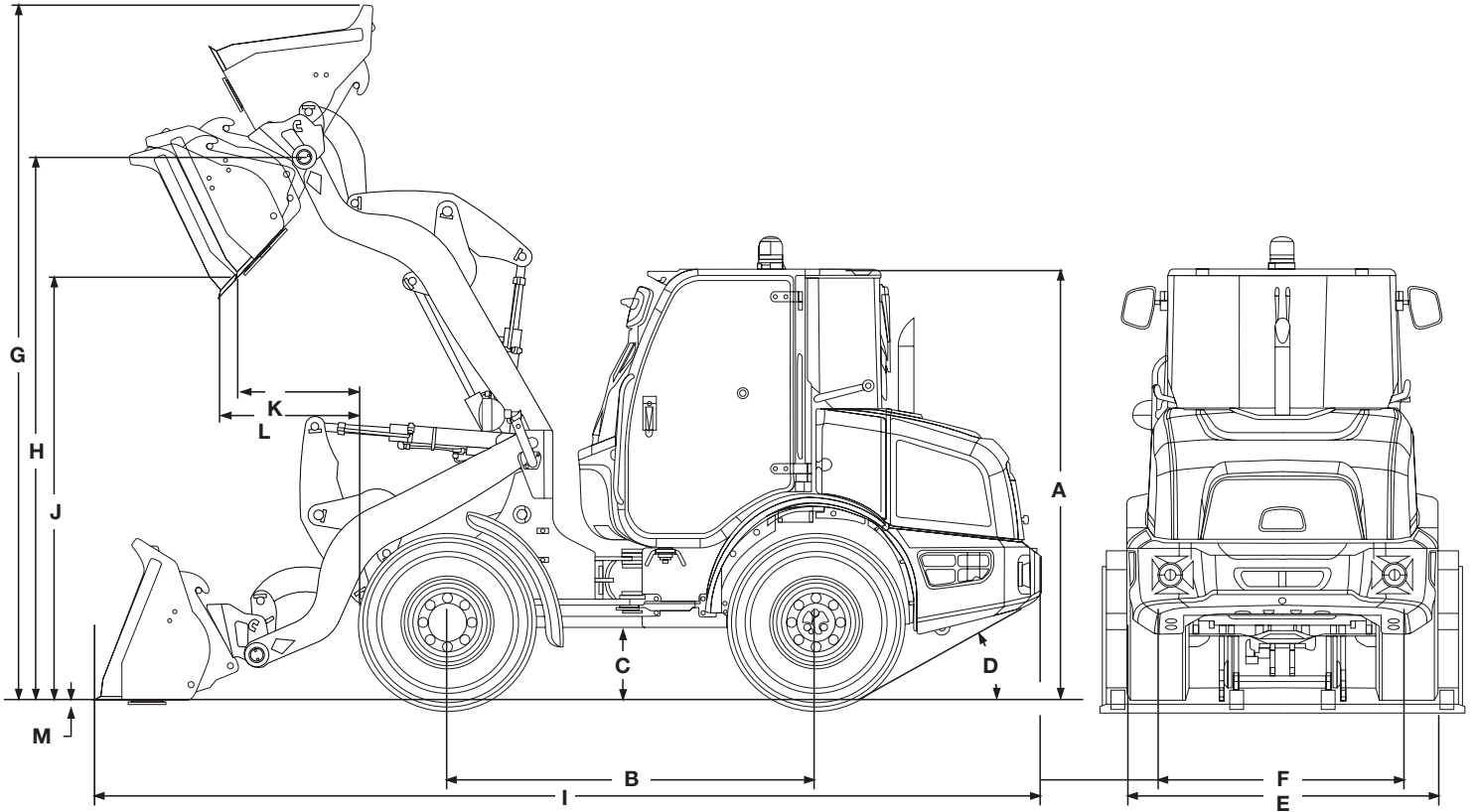

Line drawings are for illustrative purpose only and may not be exact representation of unit.

## DIMENSIONS

A. Height to top of ROPS cab	105.5 in (2 680 mm)
B. Wheelbase	87.6 in (2 225 mm)
C. Ground clearance under shaft	19.4 in (493 mm)
Ground clearance under axles	14.6 in (370 mm)
D. Angle of departure	32°
Width:	
E. Overall without bucket	73.2 in (1 860 mm)
F. Centerline tread	59.1 in (1 500 mm)
Turning radius – outside	157.0 in (3 987 mm)
Turning angle:	
From center	40°
Total angle	80°
Rear axle oscillation – total	20°

## PERFORMANCE SPECS

<b>321F Z-Bar</b>	<b>1.3 yd<sup>3</sup> GP (1.0 m<sup>3</sup>) GP Bucket with Bolt-on Edge</b>	<b>1.7 yd<sup>3</sup> GP (1.3 m<sup>3</sup>) LM Bucket with Bolt-on Edge</b>
ISO bucket capacity – struck	1.05 yd <sup>3</sup> (0.8 m <sup>3</sup> )	1.44 yd <sup>3</sup> (1.1 m <sup>3</sup> )
Heaped	1.31 yd <sup>3</sup> (1.0 m <sup>3</sup> )	1.70 yd <sup>3</sup> (1.3 m <sup>3</sup> )
Bucket width – outside	82.7 in (2 100 mm)	82.7 in (2 100 mm)
Bucket weight – includes coupler and added components	1,045 lb (474 kg)	1,142 lb (518 kg)
<b>G.</b> Operating height – fully raised with spillguard	176.0 in (4 471 mm)	182.1 in (4 626 mm)
<b>H.</b> Hinge pin height – fully raised	133.7 in (3 395 mm)	133.7 in (3 395 mm)
<b>I.</b> Overall length – bucket level on ground	234.3 in (5 952 mm)	237.6 in (6 036 mm)
Dump angle – fully raised	45°	47°
<b>J.</b> Dump height – fully raised, 45° dump	98.1 in (2 493 mm)	96.0 in (2 438 mm)
<b>K.</b> Bucket reach – fully raised, 45° dump	39.5 in (1 003 mm)	43.1 in (1 095 mm)
<b>L.</b> Bucket reach – 7 ft 0 in (2.13 m) height, 45° dump	53.0 in (1 347 mm)	55.0 in (1 396 mm)
<b>M.</b> Dig depth	3.3 in (83 mm)	3.2 in (83 mm)
Operating Load (ROC) - ISO	4,265 lb (1 934 kg)	4,316 lb (1 958 kg)
Maximum material density – ISO	3,261 lb/yd <sup>3</sup> (1 935 kg/m <sup>3</sup> )	2,538 lb/yd <sup>3</sup> (1 506 kg/m <sup>3</sup> )
Tipping load – ISO:		
Straight	10,301 lb (4 672 kg)	10,255 lb (4 652 kg)
40° turn	8,530 lb (3 869 kg)	8,632 lb (3 916 kg)
Lift capacity:		
Full height	8,354 lb (3 789 kg)	8,253 lb (3 744 kg)
Maximum reach	10,503 lb (4 764 kg)	10,406 lb (4 720 kg)
Ground	13,163 lb (5 970 kg)	12,975 lb (5 885 kg)
Breakout force with tilt cylinder	10,076 lb (4 570 kg)	9,021 lb (4 092 kg)
Maximum rollback:		
@ Ground	37°	37°
@ Carry position	44°	44°
@ Maximum reach	54°	53°
@ Full height	53°	53°
Maximum grading angle with bucket – back dragging	65°	66°
Loader clearance circle with bucket	373.9 in (9 496 mm)	376.1 in (9 554 mm)

## FORKS

<b>321F Z-Bar</b>	
Fork length	47.2 in (1 200 mm)
Fork weight – includes coupler	394 lb (869 kg)
Operating load – level ground	4,998 lb (2 267 kg)
Operating mass	13,468 lb (6 109 kg)
Tipping load – straight	7,372 lb (3 344 kg)
Tipping load – 40° turn	6,247 lb (2 834 kg)
Fork load center	19.7 in (500 mm)

